



Ultra Precision
Made by myonic

Our Vision & Mission

Vision:

We strive to be market leader in our business segments.

Mission:

We provide excellence in all we do.

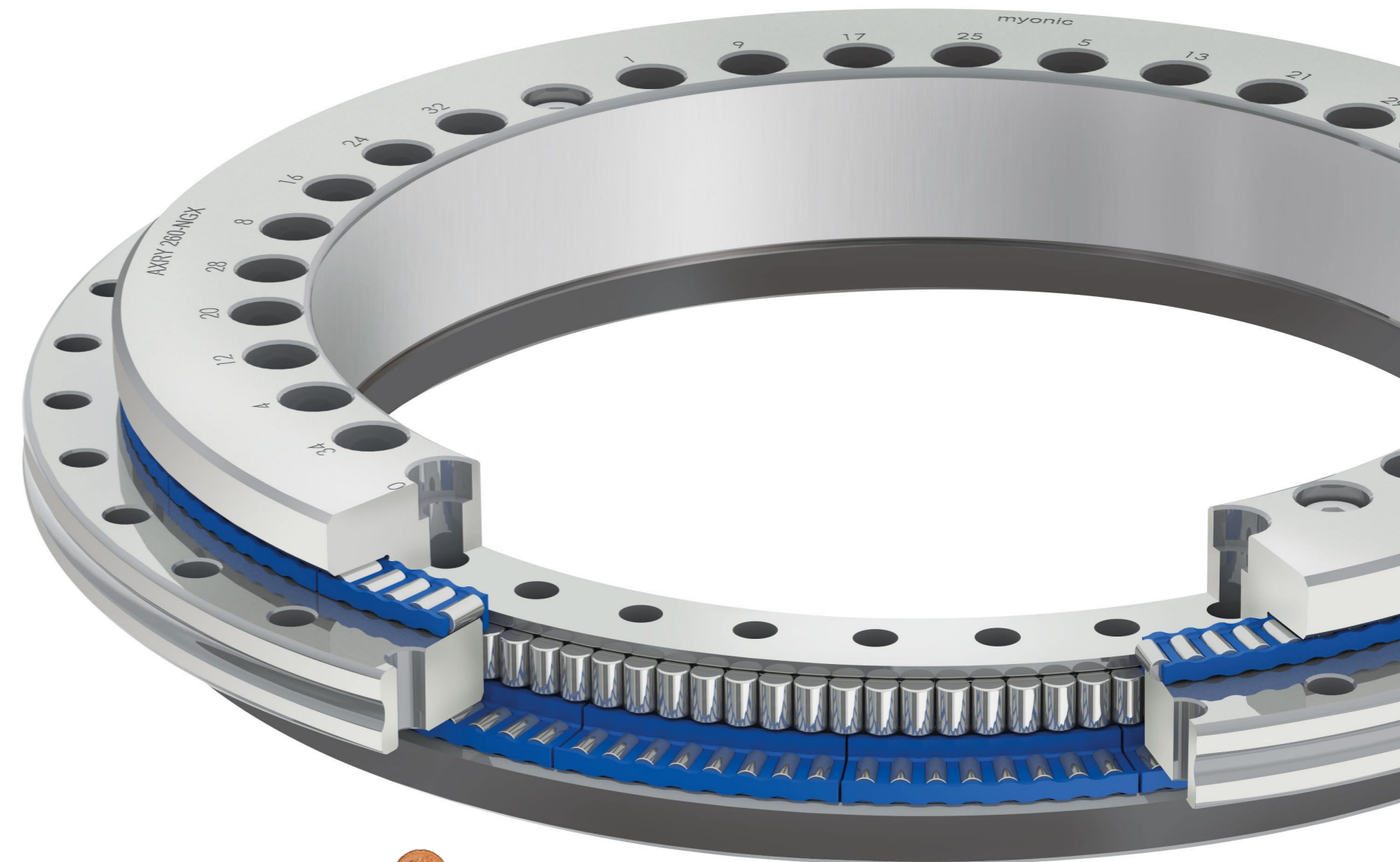

myonic bearing UL 103X shown with a 1 Eurocent piece to evidence the proportions



Size comparison 1 Euro Cent with an AXRY machine tool bearing

What we offer

- High development expertise
- Quick creation of prototypes
- Constant high quality standards
- Ultra high precision parts
- Expertise in system assembling
- Individual logistics concepts for smaller and bigger lots
- Extremely short delivery times



Our History

- 
- 1936:** Foundation of **RMB** (Roulements Miniatures de Bienne) S.A. (Switzerland)
- 1968:** Foundation of **MKL** (Miniatur Kugellager Leutkirch) GmbH by KaVo Dental GmbH
- 1971:** **RMB** S.A. acquires **MKL** GmbH, Leutkirch
- 1994:** Foundation of MPC, Roznov (CZ), renamed **myonic s.r.o.**
- 2001:** **RMB** changes to **myonic GmbH**
- 2006:** Management Buy Out with Süd Private Equity + DZ Equity Partner

Our History

- 
- 2009:** Acquisition by **Minebea Co., Ltd.** (Japan)
- 2012:** Completion of the ultra-modern new production hall in Leutkirch (Germany)
- 2013:** **myonic** acquires APB Service GmbH, Ebensee (Austria)
- 2018:** **MKL/myonic** celebrates its 50th company anniversary
- 2016/2018/** **myonic** is among the top 100 employers in Germany
- 2020/2024:** (Great Place to Work[®])
- 2023:** Record sales – strengthened from the Corona crisis
- 2024:** **myonic s.r.o. (CZ)** celebrates its 30th anniversary

The Company Structure

MinebeaMitsumi
Passion to Create Value through Difference

myonic Holding GmbH
Germany

Christoph von Appen - Managing Director

myonic GmbH
Germany

Christoph von Appen - Managing Director

myonic s.r.o.
Czech Republic

Marcela Wulfova - Managing Director
Pavel Cibulec - Managing Director

We are Part of MinebeaMitsumi Inc.

- Headquarters in Tokyo, Japan
- Founded 1951
- 183 subsidiaries in 27 countries with approx. 100.000 employees
- Umsatz 2025/26: 1.664 Mrd. Yen (ca. 9 Mrd. €)
- Ultra-precision machining and mass production technologies

Products:

- Mechanical components
(e. g. ball, rod end & spherical bearings)
- Electronic Components
(e. g. LED-Backlights, electric motors, antenna)

Applications:

- Automotive
- Aerospace
- Electronic etc.





New Hampshire Ball Bearings, Inc.
— MinebeaMitsumi Group —



Custom Bearings and Machined Products Business Unit (CBM-BU)

- International cooperation within the group
- Partner companies operate in a similar business area
- Synergy effects enable tailor-made technical and methodical solutions

myonic at a Glance

Number of employees 2025/26: 527 (by: 31.03.2026)

Sales 2025/26: Approx. 66 Mio. €

Production Sites

- Leutkirch (D): myonic GmbH (Headquarters + Production)
- Leutkirch (D): myonic GmbH (Production Machine tool components)
- Roznov (CZ): myonic s.r.o. (Assembly plant)

Sales Offices

- Chatsworth (USA): myonic USA
a division of New Hampshire Ball Bearings (NHBB Inc.)
- Further distributors and sales partners worldwide



Leutkirch (D), Steinbeisstraße

- myonic Headquarters
- Production of high precision components
- Special assembling
- Two air-conditioned production sites (10,000m²)
- Cleanroom ISO 7
- Laminar flow boxes ISO 5
- 357 employees (by 31.03.2026 – incl. Nadlerstraße)
- Certified ISO 9001:2015
- Certified ISO 14001:2015



Leutkirch (D), Nadlerstraße

- Production site Machine tool components
- 14 employees (by 31.03.2026)
- Manufacture of high-precision components for machine tools
- Bearing assembly for machine tools
- approx. 2,300m² air-conditioned
- Certified ISO 9001:2015
- Certified ISO 14001:2015



Roznov, Czech Republic

- Flexible assembling of bearings and systems
- Production of stamping parts
- Production site (3,500m²), air-conditioned
- Cleanroom ISO 7
- Laminar flow boxes ISO 5
- 168 employees (by 31.03.2026)
- Certified ISO 9001:2015
- Certified ISO 14001:2015



Sales per Market

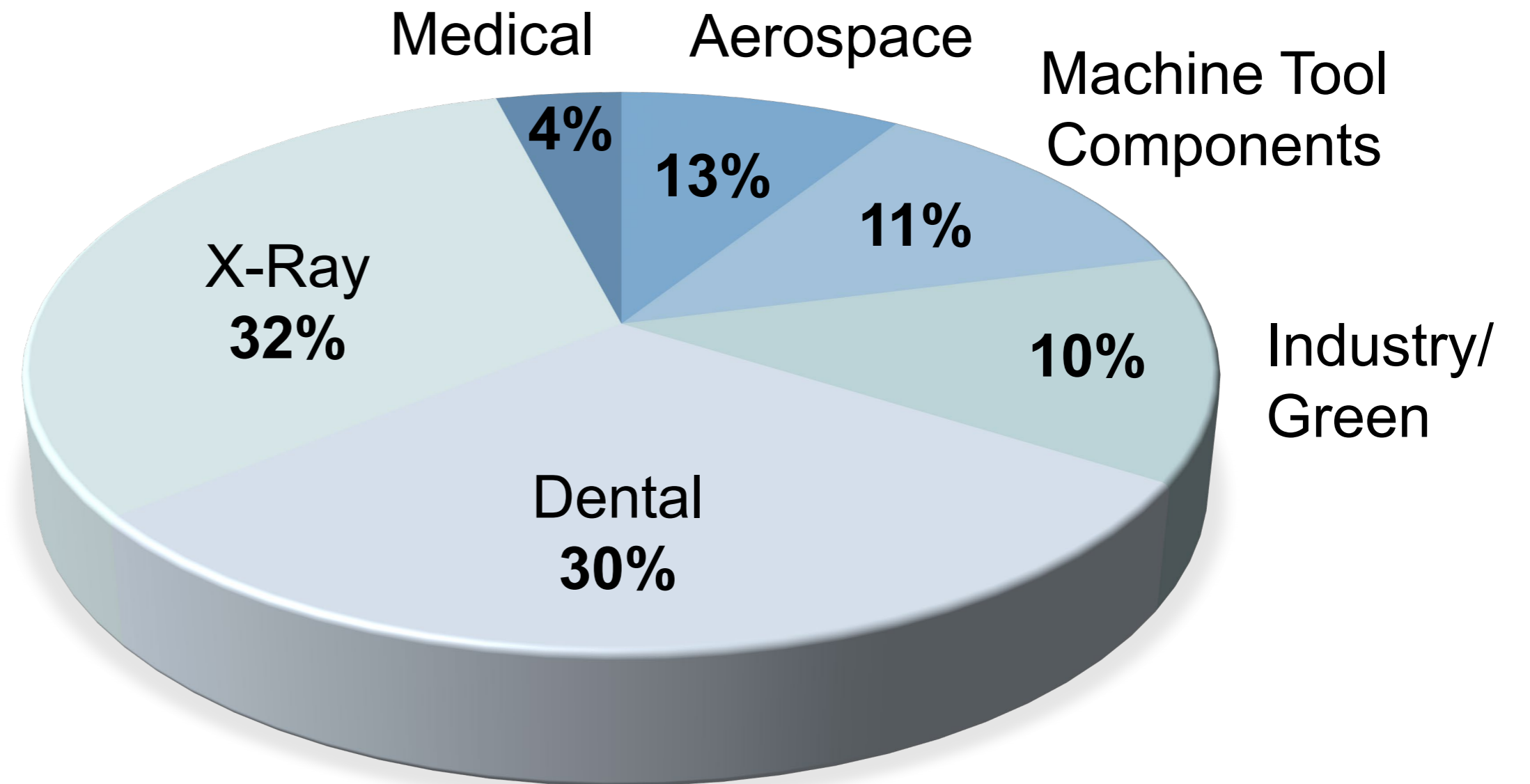

Sales per Region

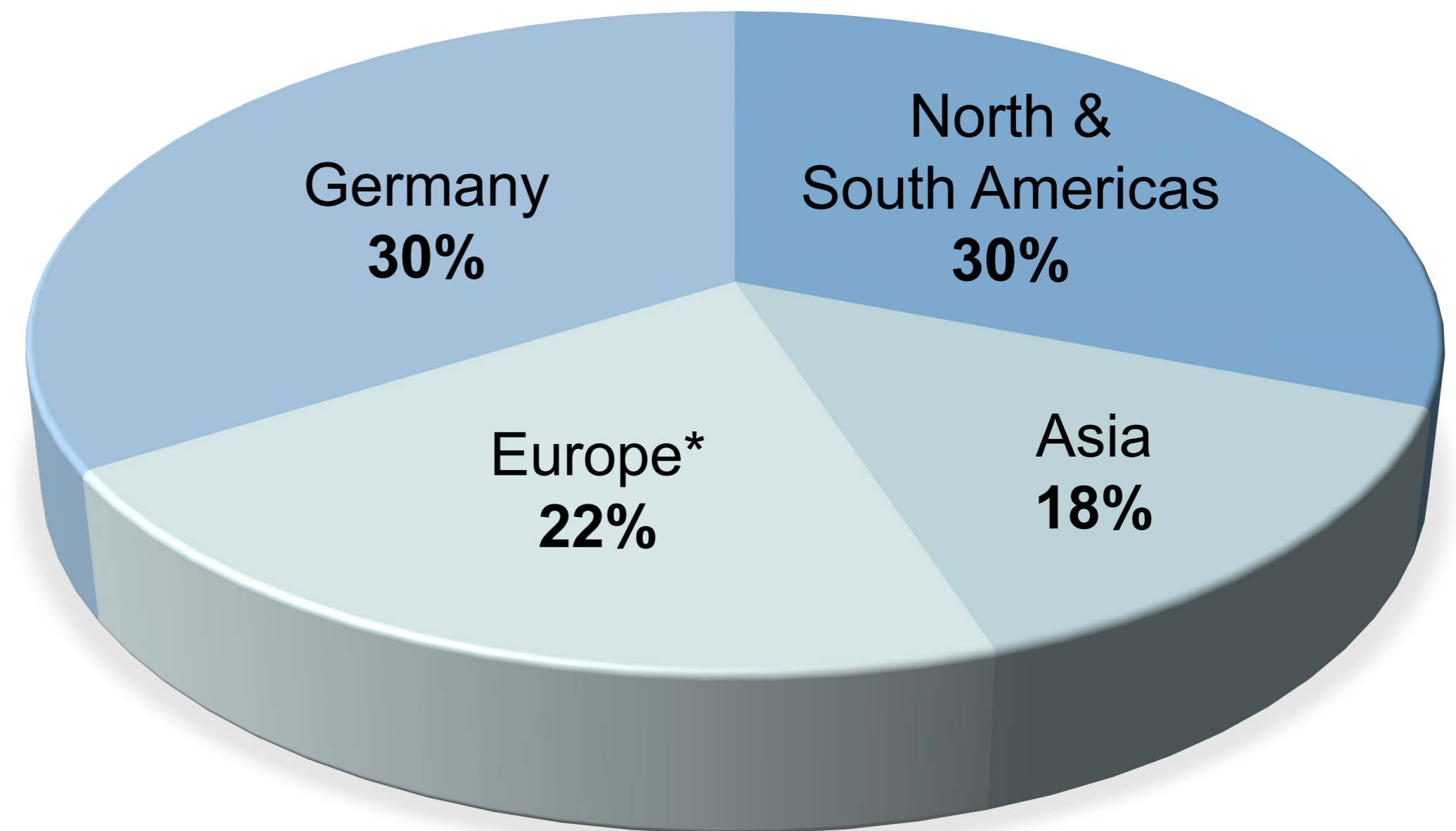

*without Germany

APPLICATIONS

Dental

- Turbine handpiece
- Angled handpiece
- Drive motors
- Surgical tools

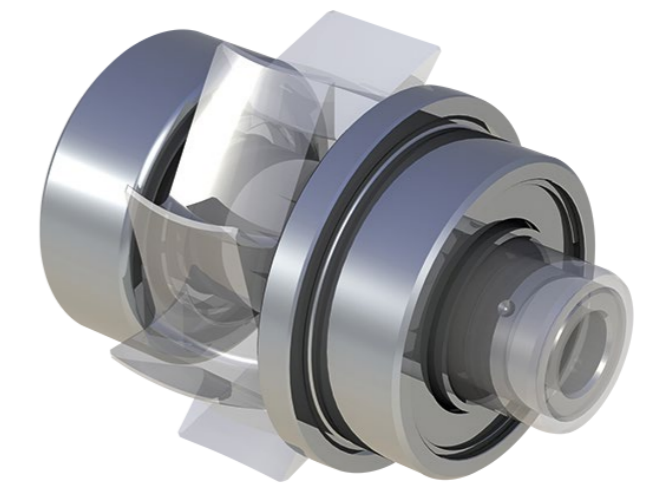

APPLICATIONS

X-Ray

- Computer tomography
- Mammography
- Diagnostics



APPLICATIONS

Medical - Special applications

- Head of an effector tool in endoscopic surgery
- Bone saw
- Components for prosthesis



APPLICATIONS

Aerospace

- Navigation Systems
- Fuel control for machinery technology
- Cryo coolers for camera systems
- Switches/relays for satellites
- Laser-aided simulation for navigation and combat

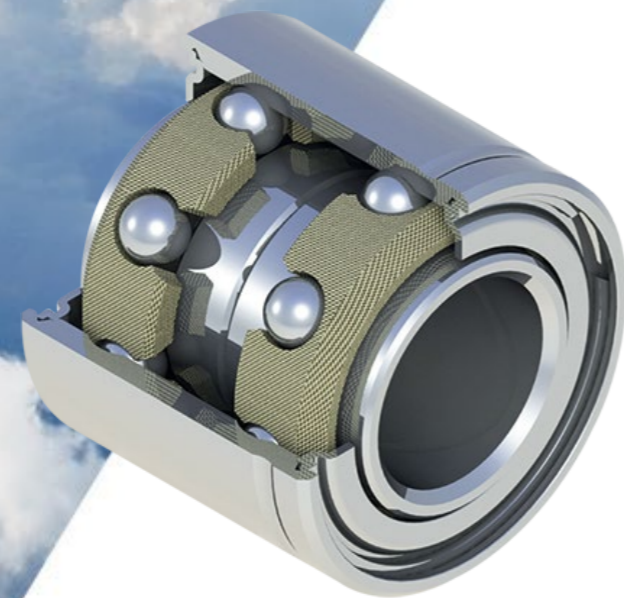
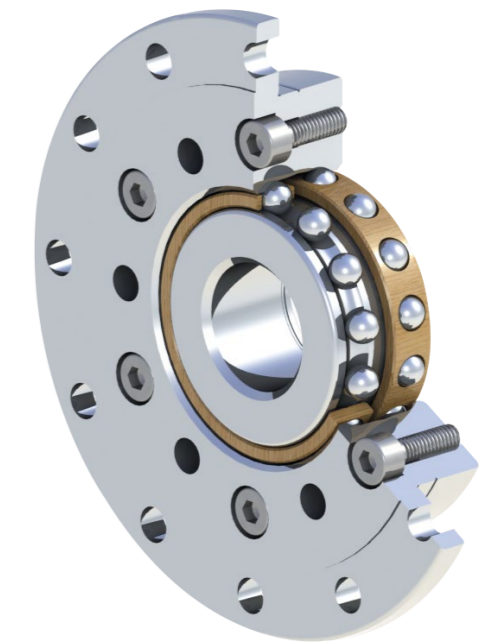

APPLICATIONS

Machine Tool Components

- Round table systems
- Rotational axes
- Linear jacking units

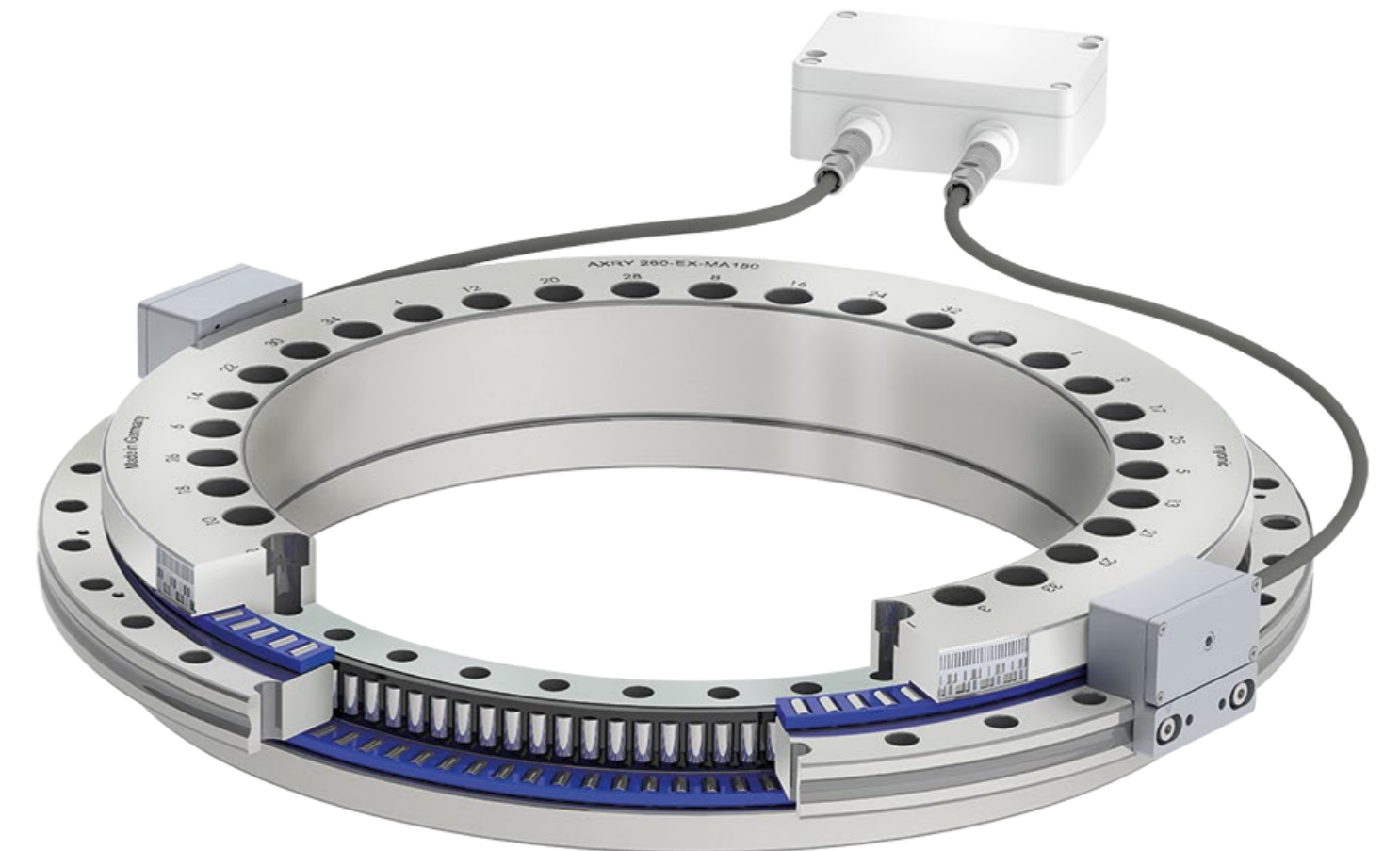

APPLICATIONS

Industry / Green

- High-speed spindles
- Gas meter
- Components for pick & place machines
- Flywheel storage
- Turbomolecular pump





Excellent employer

- 2026:** Best Employer Manufacturing & Industry (rank 3), Allgäu, Great Start! (Apprenticeship)
- 2024:** Best Employer Baden-Württemberg (rank 1), Allgäu (rank 3), Germany
- 2020:** Best Employer Baden Württemberg, Allgäu (rank 1), Germany
- 2018:** Best Employer Baden Württemberg Allgäu (rank 1), Germany
- 2016:** Best Employer Baden Württemberg Allgäu (rank 2), Germany
- 2014:** Best Employer Allgäu (rank 3)

*in our respective size class

A Great Place to Work

The challenge:

In a region with nearly full employment effective growth is only possible with adequate and motivated employees

Strategic target of myonic:

Steady improvements in the workplace culture and the quality of the employer

Central workplace topics:

Trust, identification, team spirit, career chances, payment, health promotion and work-life balance

Regular benchmark studies:

(staff surveys + HR/management/culture surveys) executed by the Great Place to Work[®] Institute rate the success of the measurements



References





Thank you for
your Attention